

Lastname: _____

LABORATORY
Intro. to SFG

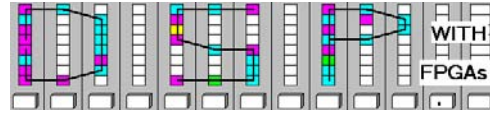

5Digit SS: _____

LAB SFG: INTRODUCTION TO SIGNAL FLOW GRAPHS
(10 points)

In this lab you will be introduced to signal flow graphs (SFG), system analysis and synthesis. DSP systems can be described by different methods. Most frequently used are the differential equation, the z-transform, and the SFG. When designing a system, the analysis of the properties of the system also plays an important role.

In the **pre-lab** you will compute with “pencil-and-paper” the results you later expect in your design implementation. In the **design part** you will design three systems and analyze their response to an impulse sequence.





Lab Objectives

After completing this lab you should be able to

- Characterize systems by linearity, stability, causality and time invariance
- Understand the difference between FIR and IIR systems
- Design and simulate nonlinear, FIR and IIR systems using Simulink

Pre-lab (5 points)

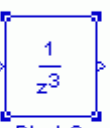
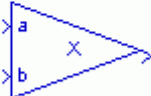
1. SFG graph are built using basic building blocks. Give a short description and the differential equation for the 5 blocks below. The gain block is given as an example. Use $a(n)$ and $b(n)$ as inputs and $y(n)$ as output.

Element	Short description	Differential equation
 Block 1	Scaling with a constant value of 1.25	$y(n) = 1.25 * a(n)$
 Block 2		$y(n) =$
 Block 3		$y(n) =$
 Block 4		$y(n) =$
 Block 5		$y(n) =$

Lastname: _____

LABORATORY Intro. to SFG

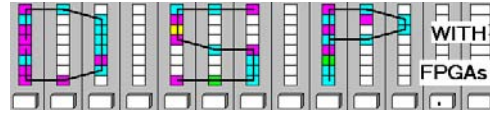

5Digit SS: _____

2. For the 3 systems A, B and C shown below, determine the response to a two impulse sequence with amplitude 10 and -20 by completing the scope plot in Fig. 2. Note that the pattern block produces a length-2 periodic sequence with 0 and 1 values.

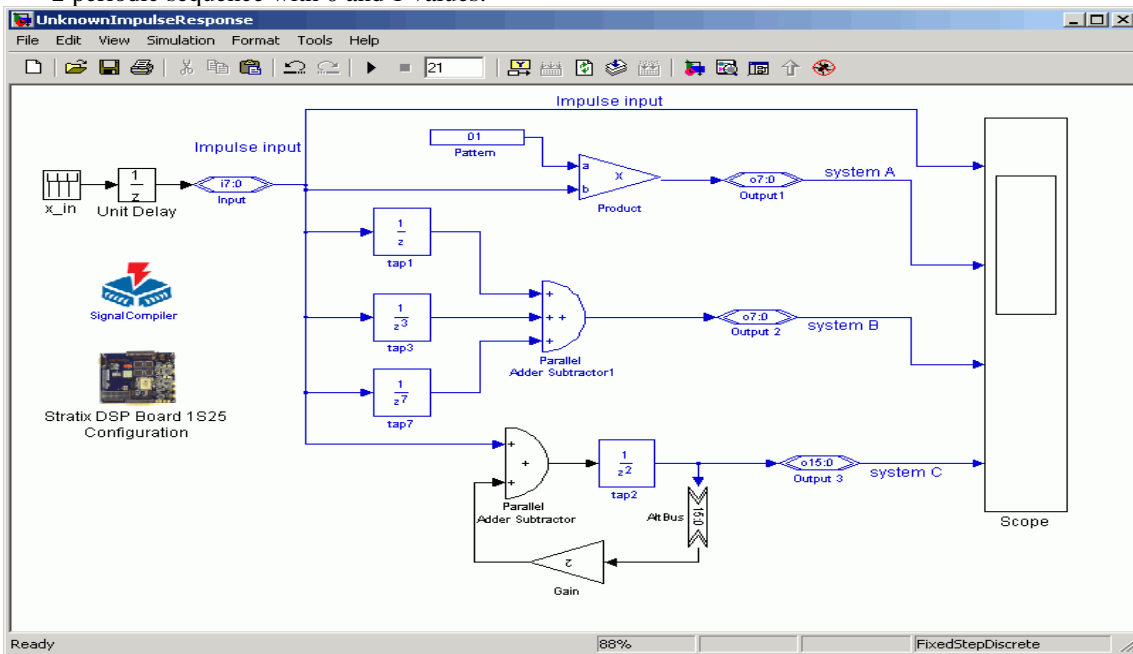

Fig. 1: Three systems with unknown impulse response.

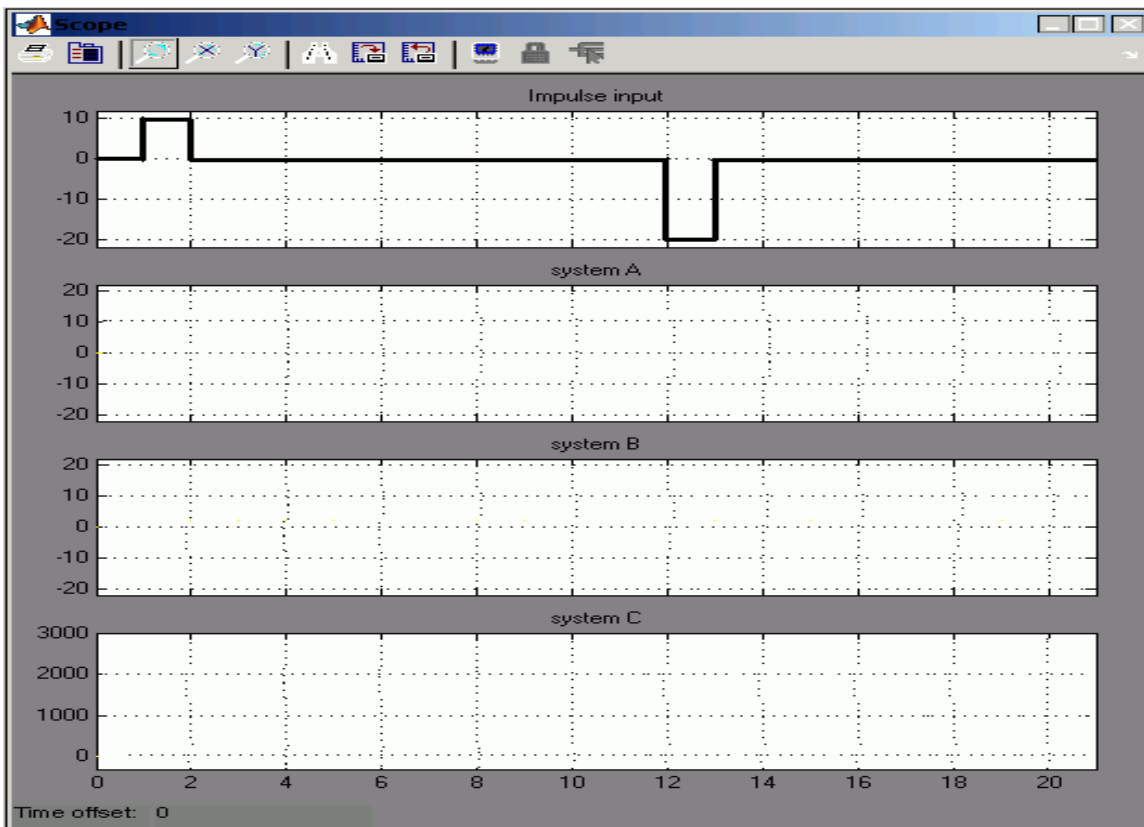
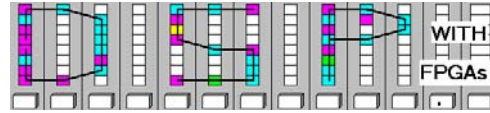

Fig. 2: Scope plot for the three unknown impulse responses.

Lastname: _____

LABORATORY
Intro. to SFG



5Digit SS: _____

3. The following figure (Fig. 3) shows three black box systems. The SFG of the systems are not known, but the response of the three unknown systems to a impulse sequence of 10 and -20 have been measured, as shown in Figure Fig.4. First determine the differential equation of the systems and then complete the three SFGs.

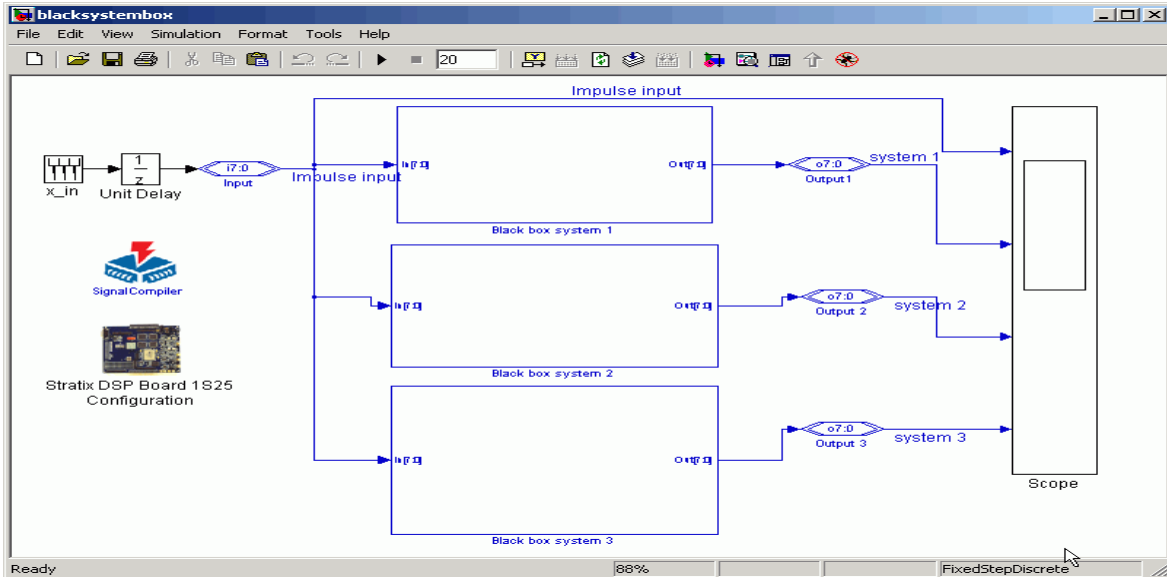

Fig. 3: Black box systems with known impulse responses.

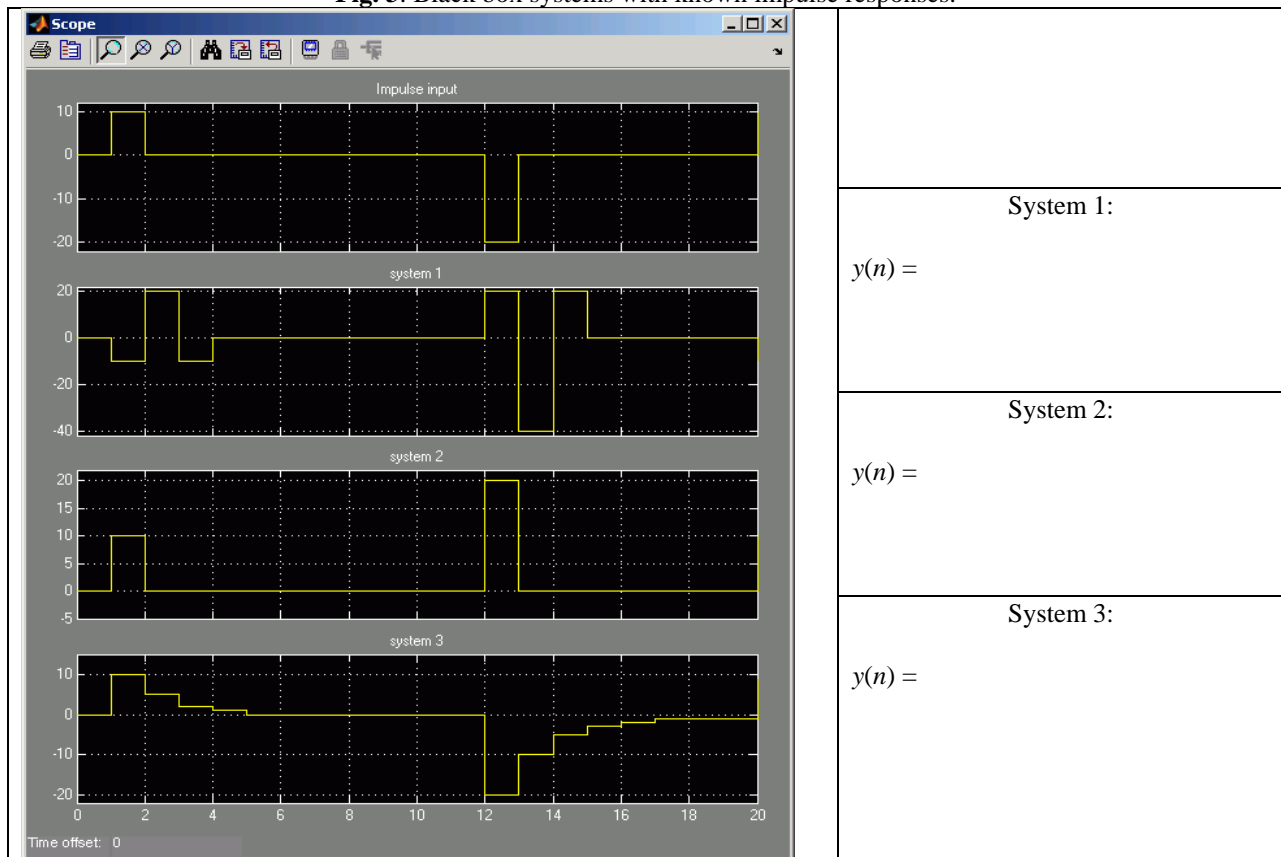
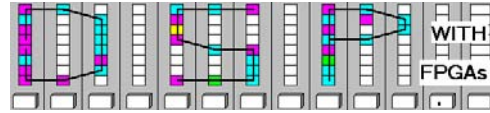

Fig. 4: Black box system measured responses to two impulse of 10 and -20.

Lastname: _____

LABORATORY
Intro. to SFG



5Digit SS: _____

Simulink Design-lab

Follow the directions below to implement the circuit shown in Fig. 3.

A. Getting Started

If you are in B114 or the digital logic lab:

1. On the desktop double click on **Engineering folder**.
2. Double click on **MatLab** icon  to start **MatLab**.
3. From the top icon list in the **MatLab** window click on the **Simulink** icon  to start **Simulink**.
4. You should not save anything on the local hard disk. You will have to use a Zip, a floppy disc, or your "mapped" home directory to save the files. Create a New Folder named **DSPwFPGAs** on your mapped network drive.

B. Design the SFG systems

1. Download the file `sfg.mdl` from the class webpage and put the file in the **DSPwFPGAs** folder.
2. Click on the "Current Directory" selection icon  and select as current directory the **DSPwFPGAs** folder.
3. The files in the **DSPwFPGAs** folder are now visible in the upper left **MatLab** window. Double click on the `sfg.mdl` file and after a moment you should see the design:

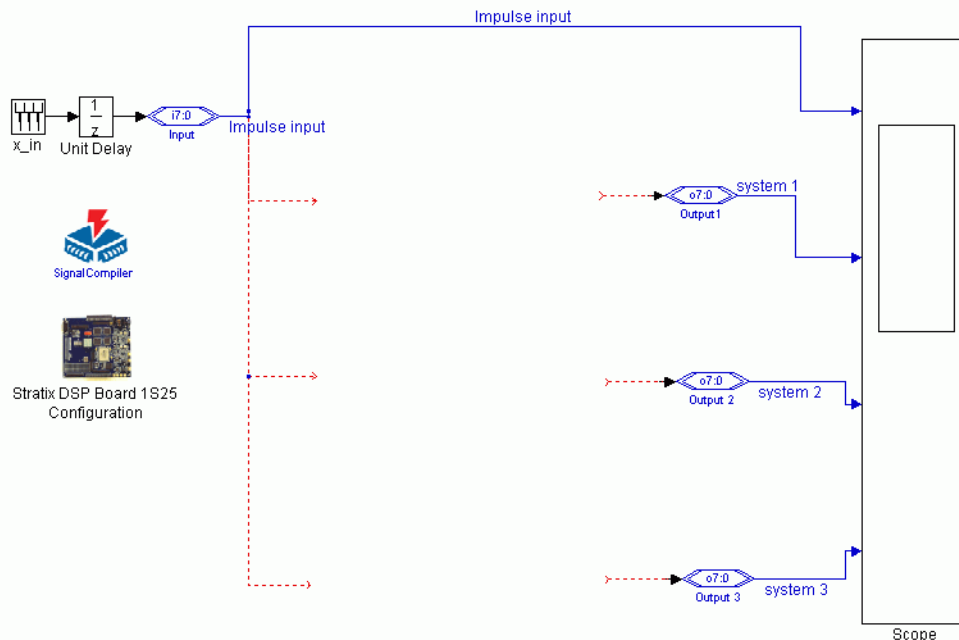

Lastname: _____

LABORATORY
Intro. to SFG

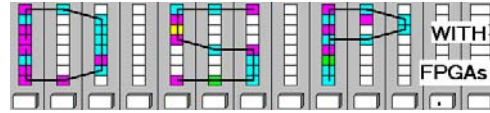

5Digit SS: _____

C. Completion of the MDF design

1. Complete your design using the signal flow graph you developed in the pre-lab for the black-box system.
2. Verify the design via a Simulink simulation. Verify the correct impulse responses as determined in the pre-lab.
3. Compile the design using **Signal Compiler** and determine

LCs = _____

MHz = _____

from the report files.

F. Deliverables:

1. Solve the problems of the pre-lab. (5 points).
2. Print the MDF file and the Simulink simulation (5 points).

Make sure your name and SS is on all pages you turn in!