

Lastname: _____

5Digit SS: _____

LABORATORY
Number Systems and
Quantization

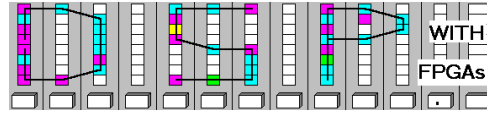

LAB : NUMBER SYSTEMS AND QUANTIZATION
(10 points)

In this lab you will be introduced to fractional number systems.
In the **pre-lab** you will compute via “pencil-and-paper” the results you later expect in your design implementation. In the **design part** you will design and simulate a 5-bit bus implementation of a fractional number system.

Lab Objectives

After completing this lab you should be able to

- understand the difference of signed and unsigned numbers systems
 - determine minimum and maximum values in integer and fractional number systems
 - compute quantization error
 - design and simulate a circuit using Simulink
-

Pre-lab (3 points)

1. The A/D converter used in our board uses a 12 bit integer **signed** data format.

a. Determine the maximum number that can represented: $X_{\max} =$ _____

b. Determine the minimum number that can represented: $X_{\min} =$ _____

2. The D/A converter used in our board uses a 14 bit integer **unsigned** data format.

c. Determine the maximum number that can represented: $Y_{\max} =$ _____

Lastname: _____

5Digit SS: _____

LABORATORY
Number Systems and
Quantization

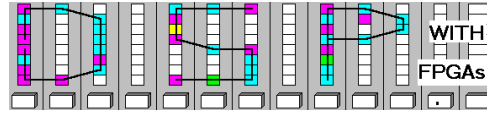

d. Determine the minimum number that can be represented: $Y_{\min} =$ _____

3. For the following signed fractional numbers with 3 integer and 2 fractional bits determine:

e. the decimal weight ($\pm 2^k$) for each digit in the signed 3.2 format: _____ . _____

f. the largest positive number in binary format $B_{\max} =$ _____

g. the equivalent of B_{\max} as decimal number $D_{\max} =$ _____

h. the smallest positive number in binary format: $B_{\min} =$ _____

i. the equivalent of B_{\min} as decimal number $D_{\min} =$ _____

j. the table values below for the 3.2 format

Decimal Value	Binary 3.2 format	Decimal 3.2 equivalent	Quantization error
2.5	___ . ___		
-1.75	___ . ___		
1/8	___ . ___		
7/3	___ . ___		

Make sure your name and SS is on all pages you turn in!

Lastname: _____

5Digit SS: _____

LABORATORY Number Systems and Quantization

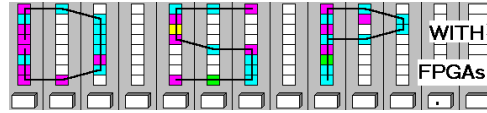

Simulink Design-lab

Follow the directions below to implement the following circuit:

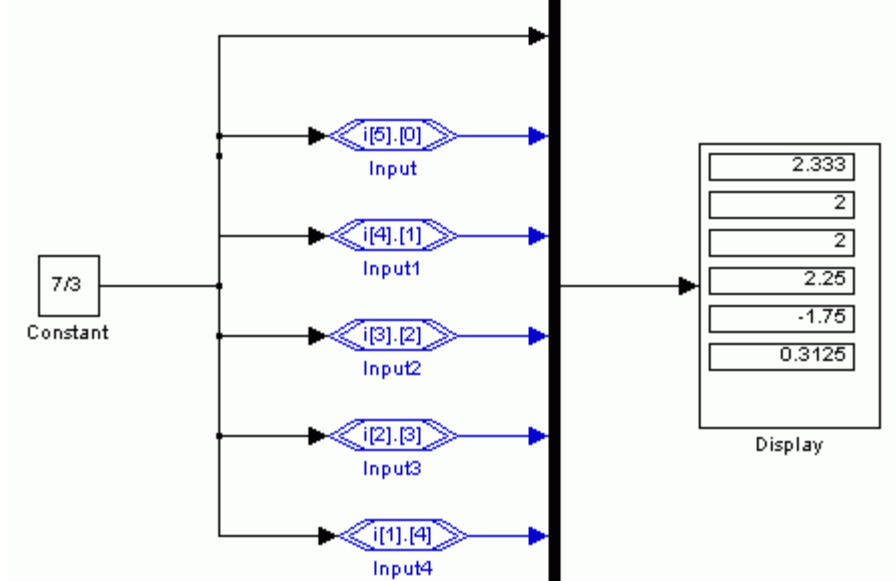

A. Getting Started

If you are in B114 or the digital logic lab:

1. On the desktop double click on **Engineering** folder.
2. Double click on **MatLab** icon  to start **MatLab**.
3. From the top icon list in the **MatLab** window click on the **Simulink** icon  to start **Simulink**.
4. You should not save anything on the local hard disk. You will have to use an USB drive, a floppy disc, or your "mapped" home directory to save the files. Create a New Folder named **DSPwFPGAs** on your mapped network drive.

B. Creating Your Simulink Design

1. Select **New Model** from the **File** menu or click on the **New Model** button in the **Simulink Library Browser**.
2. From the **Simulink Library Browser** choose the **Simulink** library and click on **Sources**. Choose the **Constant** source and drag it into your worksheet or click on the source and use **CTRL+I** to add it to the worksheet automatically.
3. To add the inputs, go to the **Altera DSP Builder** library, then **IO & Bus**. Choose the **Input** block and place 5 of them in your worksheet, or add one Input block and use **Copy & Paste** to add the remaining 4 inputs.

Lastname: _____

5Digit SS: _____

LABORATORY Number Systems and Quantization

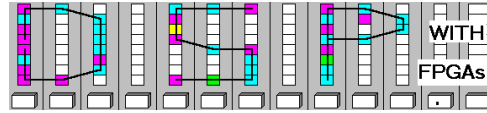

4. Wire the **Constant** source to each of the inputs by connecting wires from the output of the source to the inputs. This can also be done by clicking on the source, pressing **CTRL**, then using the left mouse key to click on the inputs to generate multiple wires from the same source.
5. To change input type and number of bits in each input, double click on one of the **Input** blocks. Change **Bus Type** to Signed Fractional and click on the Apply button. Then change the **[number of bits].[]** value to 5 and the **[],[number of bits]** value to 0 as shown below:

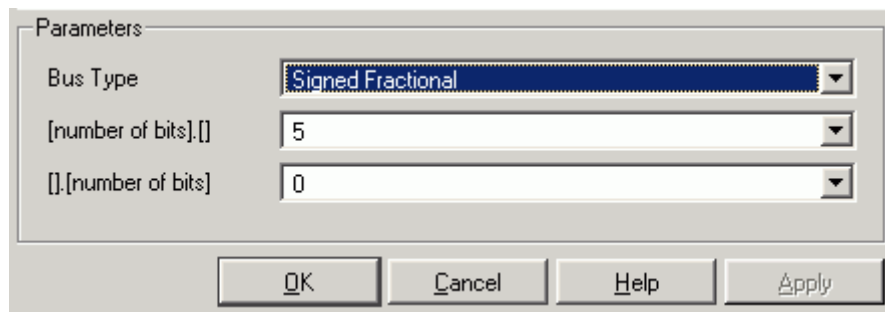

6. Repeat above step for the remaining inputs and change the bits to [4].[1], [3].[2], [2].[3], and [1].[4].
7. Under the **Simulink** library go to **Signal Routing** and choose the multiplexer (**Mux**).
8. In your worksheet double click on the multiplexer icon and change **Number of Inputs** to 6 and enlarge multiplexer by clicking on it, placing cursor on bottom or on top, and when the double-ended arrow shows up, dragging it.
9. Connect the **Constant** source to one of the multiplexer inputs and the **Input** blocks to the remaining multiplexer inputs.
10. Go to **Sinks** in the **Simulink** library and choose the **Display**.
11. Wire the **Display** to the output of the multiplexer.
12. Enlarge the **Display** icon so all values can be seen after simulation.
13. Save your design using **Save as** from the **File** menu.

C. Simulating your Design

1. Double-click on the **Constant** source and change the **Constant Value** to $7/3$.
2. On the menu bar go to **Simulation** and choose **Configuration Parameters** or use **CTRL+E** to change the parameters. Choose the following parameters as shown below:

Type: Fixed-step

Solver: discrete (no continuous states)

Tasking mode for periodic sample times: single tasking

Lastname: _____

5Digit SS: _____

LABORATORY Number Systems and Quantization

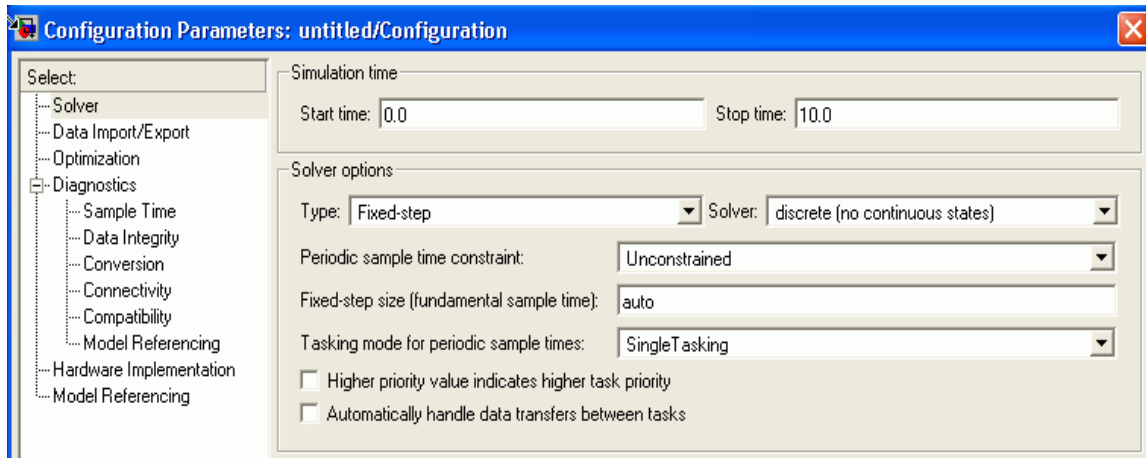
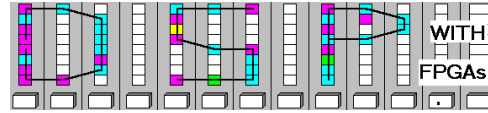

3. To simulate click on the **Start Simulation**  button, choose **Start** under the **Simulation** menu, or use **CTRL+T**.
4. Repeat steps 1 and 2 for a **Constant Value** of $5/3$, and fill out the empty scope below with the results:

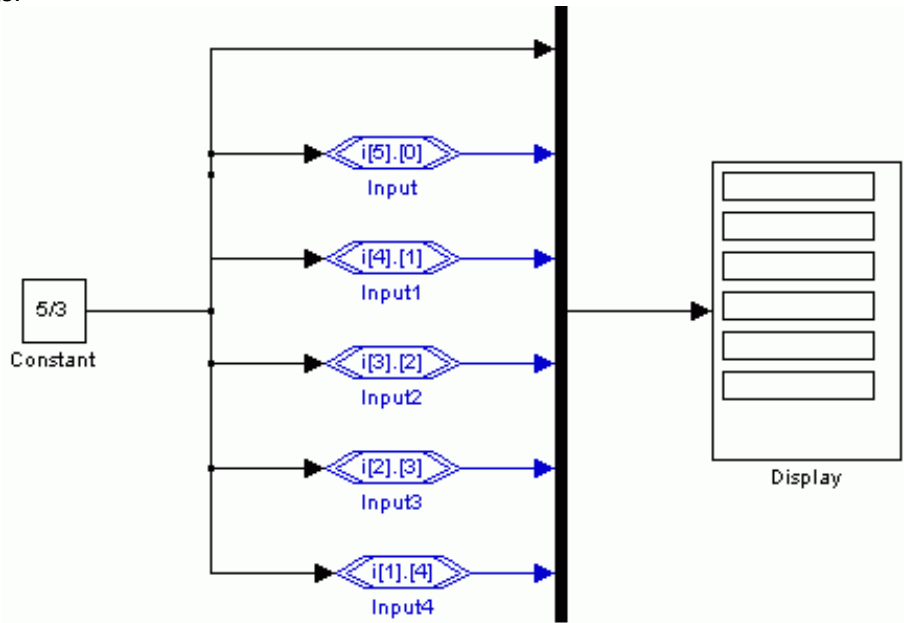

D. Deliverables:

1. Solve the problems from the pre-lab. (3 points).
2. Print the MDF file (after simulation). (7 points)

Make sure your name and SS is on all pages you turn in!